

RAY 3026a UH30b VEH30bUX 30b IN30bXUK B1 30bN 30bY GP Y OF30bYfmcZ-A G30bXI gffU BYtk cf_g56 f30bfc UY30bX

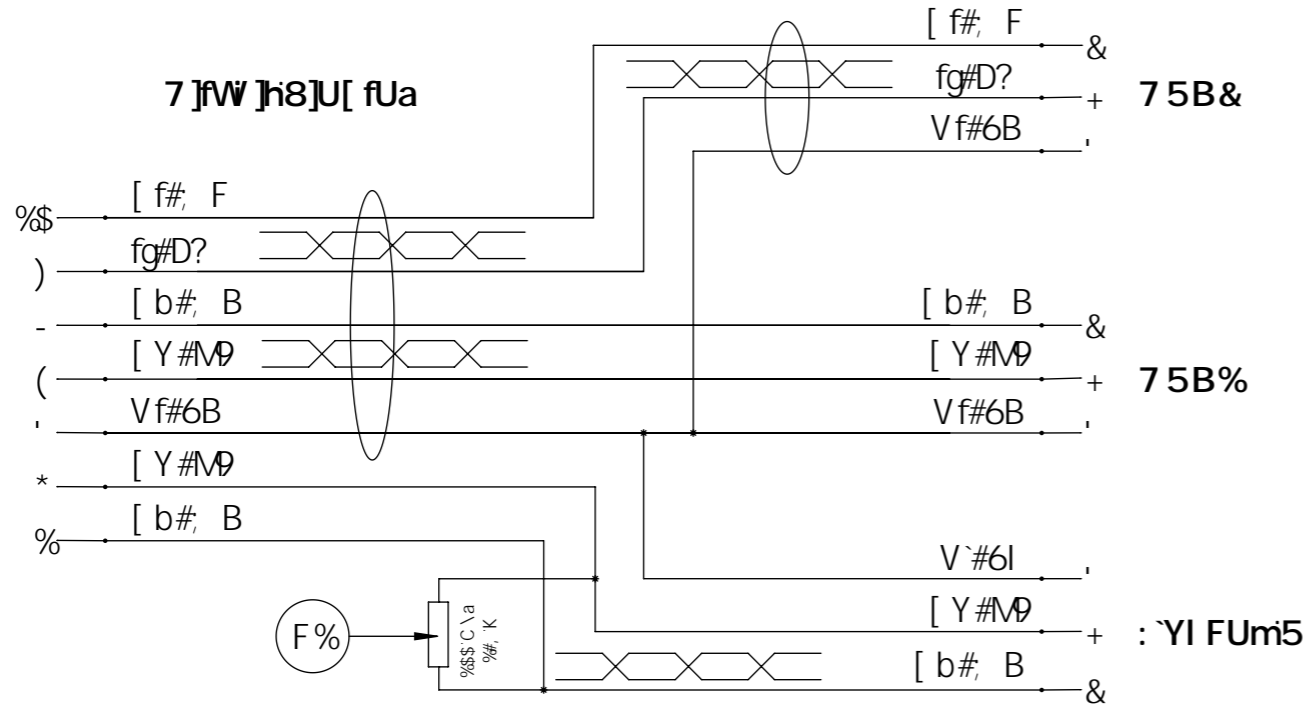
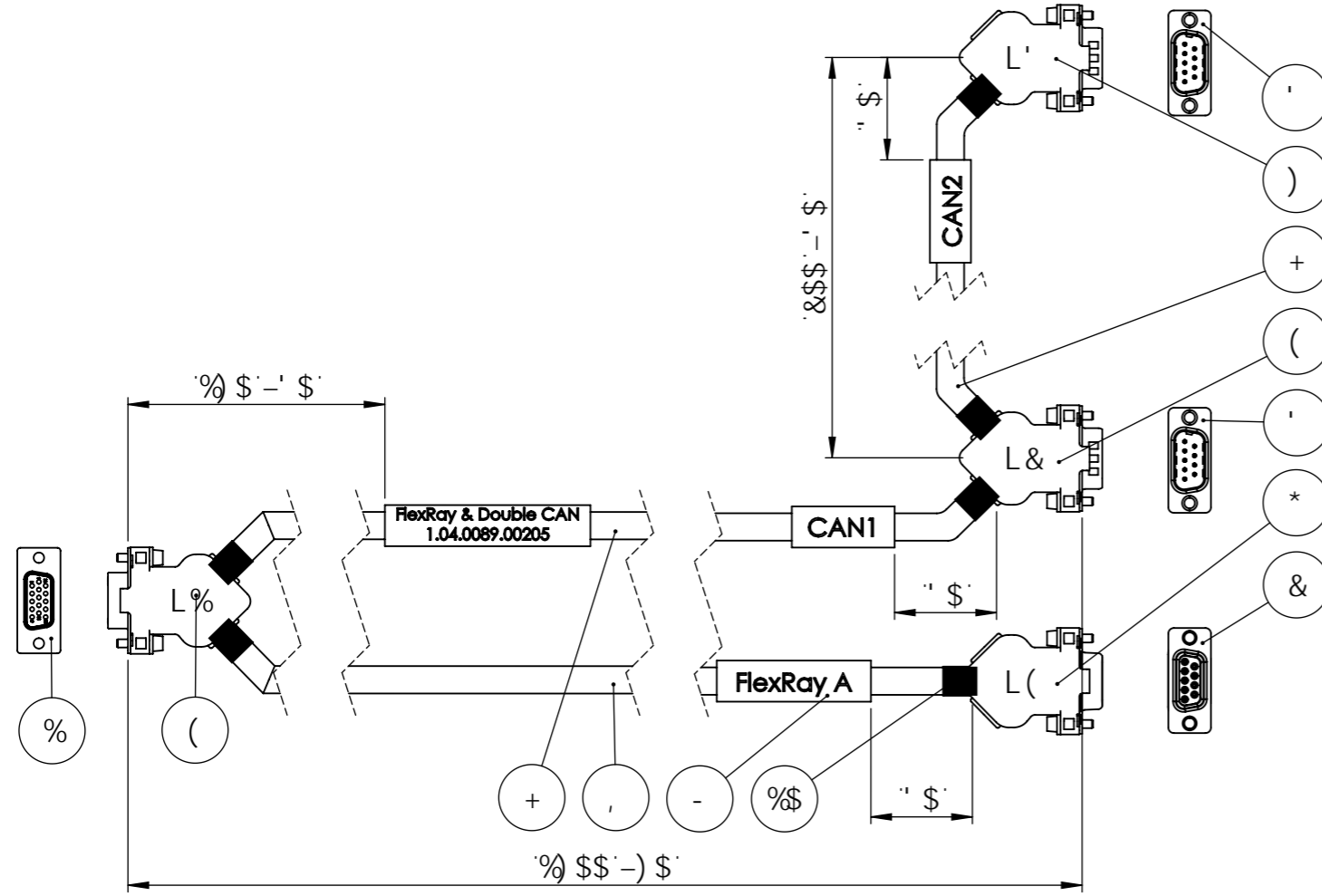

FYJ "	8YgWfdhjb	8UY	G b
%\$"&		&\$&\$!\$' !&\$	
%\$" "	7 \Ub[YX'di fWUgY'bi a VYf	&\$&\$!\$' !&\$	
%\$"(I dXUH'X XYgWfdhjb i bXYfDcg', UbX UffWY'bi a VYfcb'UVY'	&\$&\$!\$)!%	

7 cbUWhXi fUV]]mi2') \$\$'WwWYg
 G\Y'XgWcbbYWHYX'hc'a YHU``\ci glb[g'
 7 c`c'fg'Xi Y'hc'8-B'(+%\$\$'UbX'97 *\$+) +
 8 ja Ybgjcbg]b'a a 'i bYgg'chYf'gdYWZYX
 7 UVY YbXgd'fchYWHYX Vm\YUhg'f]b_'hi VY'cf'gd'ci'H'

Dcg'	E m'	8YgWfdhjb
%	%	8!Gi V]bgYfh%) !dc""<8 ZYa UY'
&	%	8!Gi V]bgYfh-!dc""ZYa UY'
'	&	8!g V]bgYfh-!dc""a UY
(&	8!g V'a YHU``Wc j Yfz'glnY%'8ci VY'WUVY'YI]h'YI 'HwC'%)' (, \$)!%
)	%	8!g V'a YHU``Wc j Yfz'glnY%'G]b[Y WUVY'YI]h'YI : 7 H: A ?%() š
*	%	8!g V'a YHU``Wc j Yfz'glnY%'G]b[Y WUVY'WbHYfYI]h'YI : 7 H: A ?%
+	%+\$Va	8UH'WUVY' I & \$Z%('ZYI]VY'UddWUVY'@M MfHdL'rk]ghYXž[fYm
,	%\$Va	:]Y'XVi g'WUVYž('Wc bXi Wci fg\$Z% a a 'rk]ghYXžZYI]VYž ŁL5H&'\$- "\$\$\$\$'%%&+
-	(@UVY`k \]h'žg'f]b_'hi VY
%\$	*	G\]b_'hi VY
F%	%	FYg]g'c'fz'%\$\$'C \ a '%#, 'K
%%	%]bX]]]Xi U`dUW_U[]b[]b'9G8!Wc'a d]UbhVU[

Ck byf

<A G30bXI gffU"BYtk cf_g56

GUH30bq UHUb' -
 G' \$&() <U'a gUX
 H' : Z('fB'!) !%& - \$\$
 :Ul : Z('fB'!) !%& - \$-

hms

G b F]5	8UY &\$&\$!\$&!%	FYJ " %'\$"(GYYh %c Z%	8cW a Ybbbf G8<!, - % !\$\$) IA \$	-A Gbf %'\$("\$\$, - "\$\$\$&)
-------------	---------------------	-----------------	---------------	---------------------------------------	-----------------------------------

1 B@9G C H: 9F K -99 GD97 = 98
 8 A 9B GC BG 5F 9' B
 A @9A 9HFG
 HC @9F 5B 7 9. 2 #1 \$Z%

h'YI
 ŁL5H<8%) '8ci VY'75B Ž: F'7 UVY

:]bUa b : G8<!, - % !\$\$) IA \$